

PRODUCT FLYER

Energy

Certification of Process GCs and direct energy meters

Custody transfer of natural gas is increasingly based on delivered energy. MID and new recommendations provide new and more flexible certification possibilities for Process Gas Chromatographs and direct energy meters.

Direct measurement of energy

Direct measurement of energy has long been an aspiration in the world of gas. Fortunately, the OIML Recommendation R137-1 "Gas meters" takes into account the possibility of gas meters reading directly in energy units. The requirements for certification of direct energy gas meters are identical to the existing direct mass and volume gas meters. NMI, closely involved in the development of this recommendation, is ready to assist you in bringing your new energy gas meter to the market.

Certification options for process GCs

For process GCs the market requires either OIML R140 or ISO 10723. In addition there may be additional, requirements due to customer specifications and national legislation. NMI will integrate all the requirements into one test plan, thus saving time and money.

Certification under MID

Although energy is not part of MI-002 it is still possible to certify a GC under MID. This is shown in the right figure where a process GC is configured as a peripheral for a Volume Conversion Device (VCD). The process GC continuously reports the current composition of the gas to the VCD in order to calculate the compressibility of the natural gas. This type of certification can be done under MID and the instrument will get an "evaluation certificate", just like pressure and temperature transmitters associated with a VCD.

Harmonized

In the past years much effort has been put into the development of recommendations and standards. As a result OIML R137-1 is now applicable to (direct energy) gas meters, OIML R140 and ISO 10723 can be applied to certify GCs, and other Calorific Value Determining Devices (CVDDs) can be certified according to OIML R140. Additional national legislation and client specific requirements may be applicable, which NMI will include in the certification process upon request.

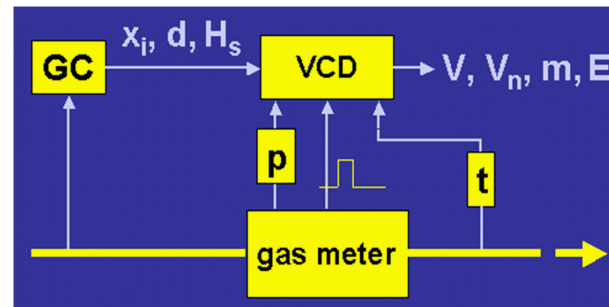

A great advantage for manufacturers is that the process GC – if measuring and transmitting gas compositions – can be manufactured and placed on the market under MID.



What NMI offers you

In the field of process GCs and direct energy metering, NMI offers you the following services:

- MID Evaluation Certificates
- MID test reports
- OIML test reports
- ISO test reports
- Type Approval Management
- STEEC
- Training
- Consultancy
- Calibration gases, e.g. synthetic natural gases
- GC calibrations, e.g. multipoint calibrations



Transparency in our services: clarity in advance!

NMI always informs you about the project steps in advance. We are happy to work, with prior agreement, on investments, test programs and time schedules. Before starting tests, we can issue a draft Type Approval Certificate that is based on your documentation. This means that you already know what the certificate will look like if your instrument complies with the requirements.

NMI thinks ahead

In order to achieve a minimum time to market, it is vital that your design already complies with the legal requirements in the target countries. NMI can assist you at this stage, thus avoiding costly modifications to your design during the type approval process.

STEEC: Standard Type Examination & Evaluation Certificates

NMI uses STEEC as a method to provide structure in your approval documents. This method gives you a clear view on the consequences of a product modification. STEEC defines three levels:

- **Essential Parts:**
If an essential part has to be modified, revision of your certificate is needed as these modifications have an impact on the metrological aspects of your product.
- **Conditional Parts:**
The conditions under which this part can be used or attached are mentioned in your certificate. Changes to this condition could lead to small revisions of your certificate.
- **Non-Essential Parts:**
Modifications in non-essential parts have no consequences for your certificates. You are free to modify these parts. The modification has no effect on the metrology aspects of the product.



Where will your MID approval be valid?

EU Countries

Austria	Germany	The Netherlands
Belgium	Greece	Poland
Bulgaria	Hungary	Portugal
Cyprus	Ireland	Romania
Czech Republic	Italy	Slovakia
Denmark	Latvia	Slovenia
Estonia	Lithuania	Spain
Finland	Luxembourg	Sweden
France	Malta	United Kingdom

EFTA Countries

- Iceland
- Liechtenstein
- Norway
- Switzerland

NMI Certin B.V.
 Hugo de Grootplein 1
 P.O. Box 394
 3300 AJ Dordrecht
 The Netherlands
 T +31 78 633 23 08
 F +31 78 633 23 09

More information?
 Would you like more information
 about our service?
 Or would you like an appointment
 with one of our consultants?

Please contact:
 NMI Certin B.V.
 Sales department
 T +31 78 633 23 08
 F +31 78 633 23 09
 E certinsales@nmi.nl
 I www.nmi.nl

TRUE VALUE
 + Testing + + + + +
 + Certification + + + + +
 + Calibration + + + + +
 + Training + + + + +